

# Receivers with Push-Lock Stud

TENSIONER

Field installed Push-Lock studs require no swaging or special tools.



## No field swaging

Similar to our Invisiware® receivers (see page 9), but when used with Push-Lock studs there is no need to swage the threaded stud onto the cable. Receivers with Push-Lock swageless studs can be used with any fitting on the other end, but **when used with our other swageless fittings, both ends can be put on the cable by hand** without any swaging or special tools.

## Easy to install

Push-Lock studs are designed for use with 1x19 L.H. lay strand only. Push the cable into the Push-Lock swageless stud, where it will be securely held inside the fitting. The receiver is female-threaded to accept the male-threaded end of the fitting. The head of the receiver is broached for an Allen wrench. To tension the cable, use an Allen wrench to rotate the receiver around the threaded end of the stud.

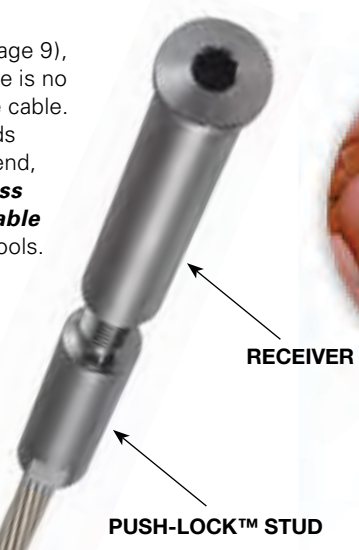

Swageless Fittings

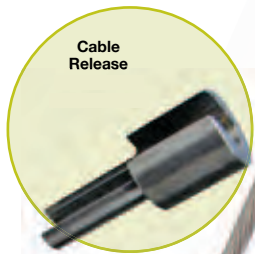

Illustrated with Push-Lock stop-end (non-tensioning) fitting on other end.

## Use with metal or wood posts

The receiver with Push-Lock stud rests inside your metal or wood end post.

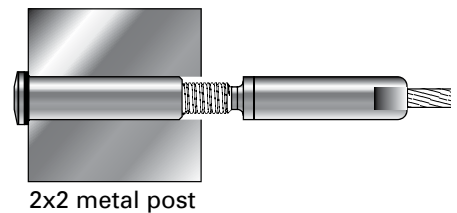

2x2 metal post

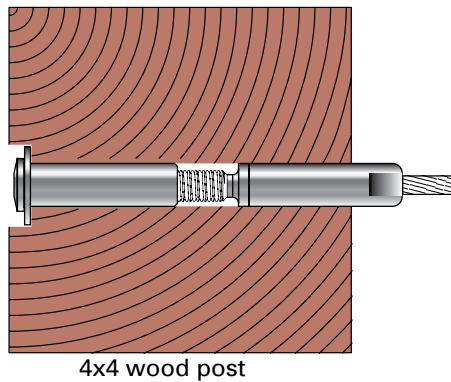

4x4 wood post

For use in wood, the fitting can rest against the outside of the end post or the post can be counterbored with the fitting recessed in the post. For wood applications, a larger diameter washer is needed to distribute the load over a wider surface. See 7/16 SAE stainless steel washer (page 21).

6  
3/1/12

ISO 9001: 2008 Certified / U.S.A. Manufacturer

**Ultra-tec®**  
CABLE RAILING SYSTEMS

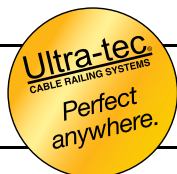

1-800-851-2961 ■ 775-885-1443 ■ Fax 775-885-2734  
52 Heppner Drive ■ Carson City, NV 89706  
E-mail: info@ultra-tec.com Website: www.ultra-tec.com

## For stairs or severe pitches

With wood posts, you need to counterbore a 1" diameter hole at an angle, to accept the over-sized stainless steel washer that distributes the load over a wider surface than is required with a metal post.

Special stainless steel beveled washers let you use Push-Lock tensioners on stairs or severe pitches with flat-sided metal posts. (Not offered for pipe or round tubing.)

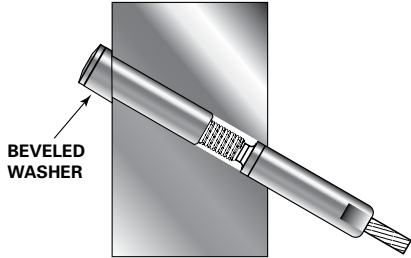
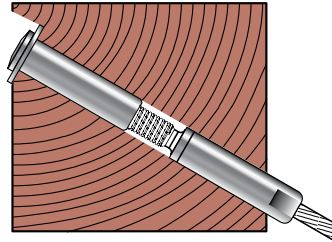

### STAINLESS STEEL BEVELED WASHERS

FOR PITCH OF	ORDER PART NO.
30° - 33°	<b>BW32-6</b>
34° - 36°	<b>BW35-6</b>
37° - 39°	<b>BW38-6</b>

## For level runs

Receivers with Push-Lock studs rest in a hole inside the end post. Pipe ends are counterbored, so the full perimeter of the screw cap head rests on a flat surface in the pipe. The head rests on the outside wall of a flat-sided metal post. A plastic washer is included and acts as a scratch-resistant barrier between the screw cap head and the metal post. For wood applications, a larger diameter washer is needed to distribute the load over a wider surface. For wood, also order part No. 7/16 SAE stainless steel washer.

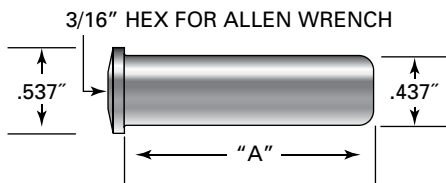
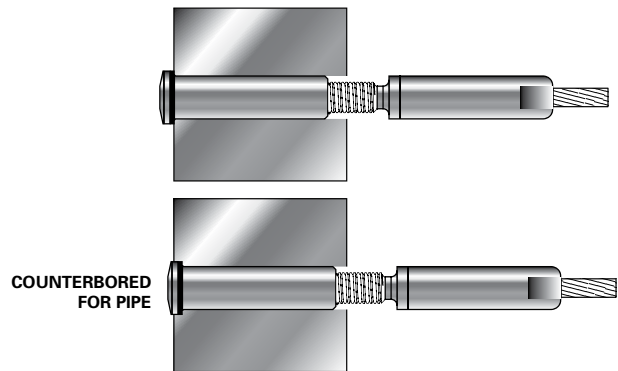

Invisiware® Receivers are made of type 316 stainless steel.  
PART NUMBERS IN BOLD TYPE. ORDER SWAGELESS STUD SEPARATELY.

CABLE DIA.	USE WITH SWAGELESS STUD NO.	A = LENGTH OF RECEIVER BODY							
		1.582"	1.812"	2.030"	2.301"	2.375"	2.530"	3.030"	3.5625"
1/8"	<b>PLST-4</b>	R-6-12	R-6-22	R-6-32	R-6-42	R-6-72	R-6-82	R-6-52	R-6-62
3/16"	<b>PLST-6</b>								

## Push-Lock Swageless Stud

The Push-Lock swageless stud is installed onto the end of the cable by hand, by pushing the cable into the fitting where it is held securely inside. No swaging is required, and, other than a cable cutter, no special tools are needed.

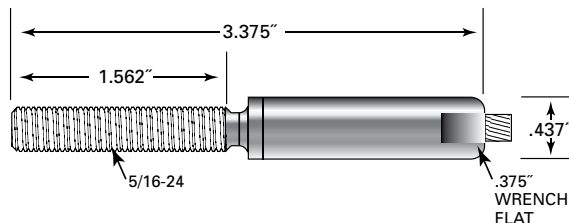

Push-Lock™ swageless studs are made of type 316 stainless steel with the exception of internal components that are made of other types of stainless steel.

**DESIGNED FOR USE WITH 1X19 L.H. LAY STRAND ONLY**

CABLE DIA.	PART NO.
1/8"	<b>PLST-4</b>
3/16"	<b>PLST-6</b>

ISO 9001: 2008 Certified / U.S.A. Manufacturer

1-800-851-2961 ■ 775-885-1443 ■ Fax 775-885-2734

52 Heppner Drive ■ Carson City, NV 89706

E-mail: info@ultra-tec.com Website: www.ultra-tec.com

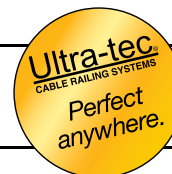

**Ultra-tec**  
CABLE RAILING SYSTEMS